

P1,P2: M-Y123A
M-126A
P3: M-300B

Customer No: No.1

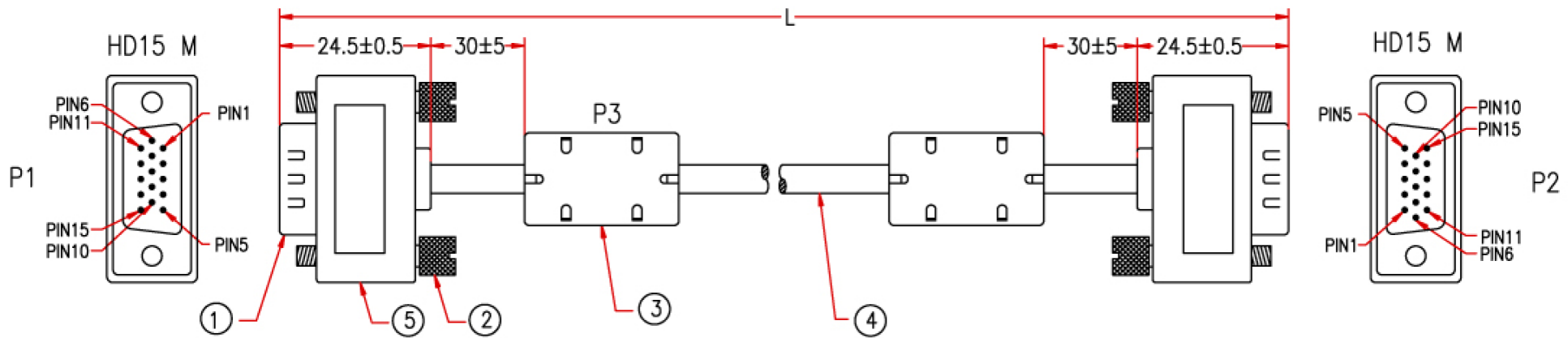

P1		9B56-2		P2	
1	—	1	RED CONDUCTOR	1	RED CONDUCTOR
6	—	6	RED SHIELD	6	RED SHIELD
2	—	2	GREEN CONDUCTOR	2	GREEN CONDUCTOR
7	—	7	GREEN SHIELD	7	GREEN SHIELD
3	—	3	BLUE CONDUCTOR	3	BLUE CONDUCTOR
8	—	8	BLUE SHIELD	8	BLUE SHIELD
4	—	4		4	
5	—	5		5	
9	—	9		9	
10	—	10		10	
11	—	11		11	
12	—	12		12	
13	—	13		13	
14	—	14		14	
15	—	15		15	
SHIELD	—	SHIELD		SHIELD	

* NOTE: All relevant materials are complied with RoHS directive .

5	BLACK HEAT SHRINK TUBE ϕ 3.0*5mm	6	M743
	BLACK HEAT SHRINK TUBE ϕ 1.0*5mm	6	M743
	BLACK HEAT SHRINK TUBE ϕ 3.0*10mm	2	M743
	COPPER FOIL 17*65mm	2	M309
	MOLDED PE COLOR TRANSPARENT		M280
	MOLDED PVC BLACK		M304
4	UL20276 [32AWG(1C+D+FAM)*3C+9C*30AWG]+AL+D+B, OD 4.6mm, JACKET BLACK	L-20mm	M298
3	FERRITE CORE 12*5.6*20mm	2	M113
	MOLDED PVC BLACK		M304
2	SCREW #4-40, LENGTH 6.25*25.5mm	4	M95
1	HD15 MALE WITH THREADED NUT(2pcs) INSIDE, 4.75*5.5mm, GOLD FLASH ON CONTACTS, METALLIZE TYPE, BLUE INSULATOR	2	M108
No.	DESCRIPTION	Q'TY	Supplier
APPROVED		Cable Length Unless Other Spec. Tolerances: 0 ~200mm \pm 10mm 201~1000mm \pm 20mm 1001 ~1500mm \pm 25mm 1501~2100mm \pm 30mm 2100mm \uparrow \pm 40mm	
CHECKED			
DRAWING			
DATE	23/JUL/09	ITEM NO.	
		UNIT:mm	

CHECKED