

# Polarity Methods For MTP System

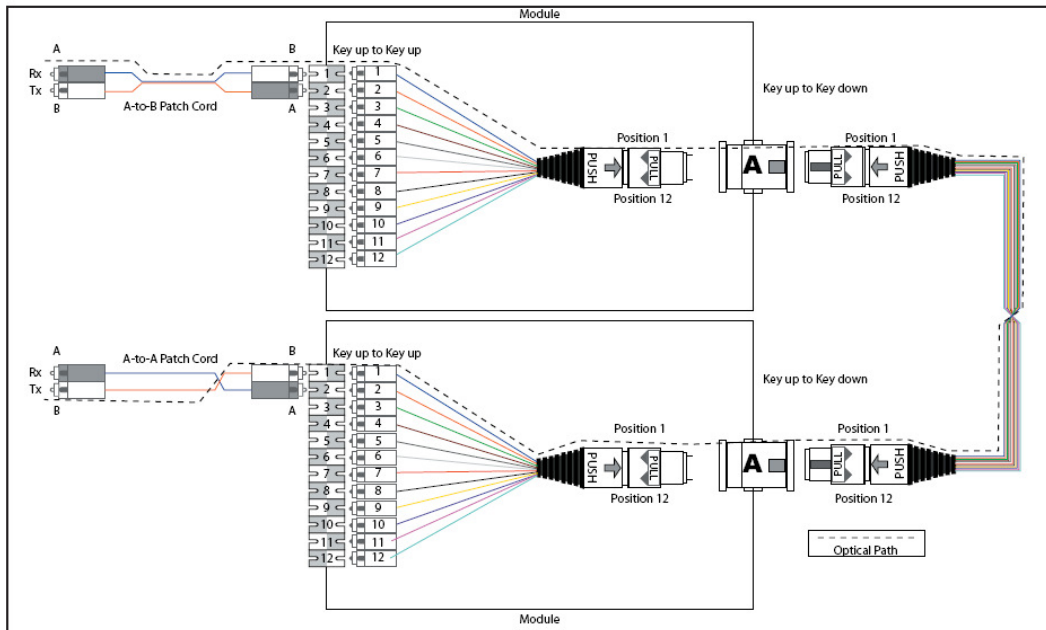

Figure 1: Method A Connectivity

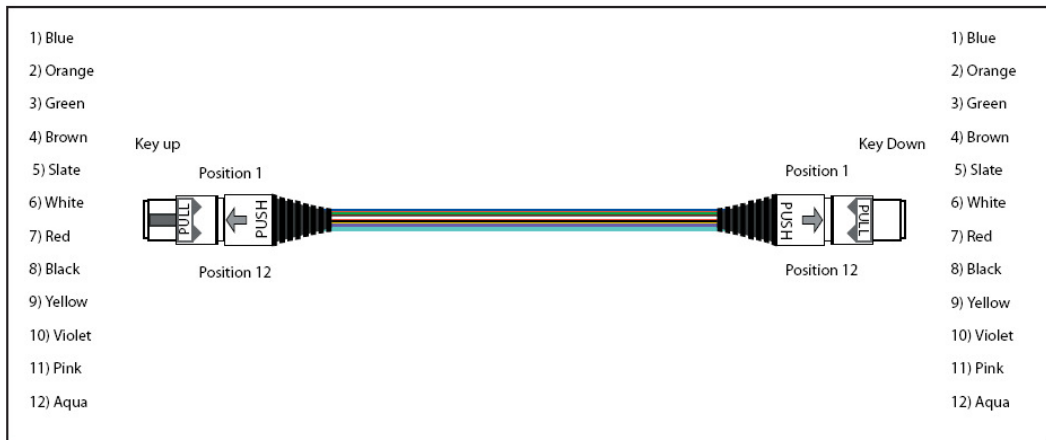

Figure 2: Method A Backbone

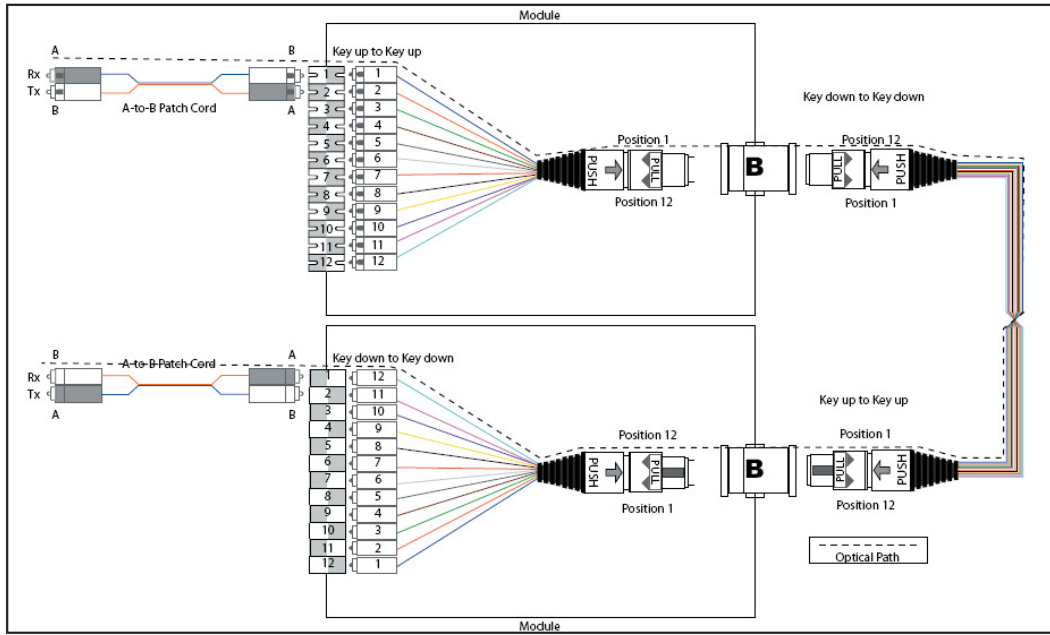

Figure 3: Method B Connectivity

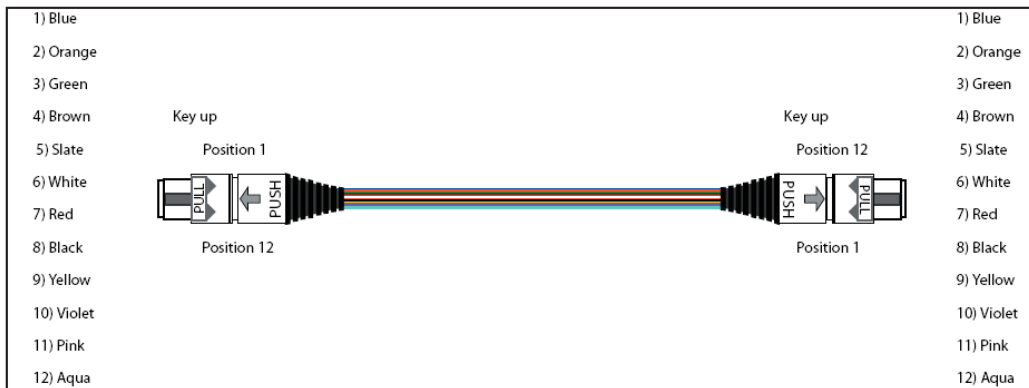

Figure 4: Method B Backbone

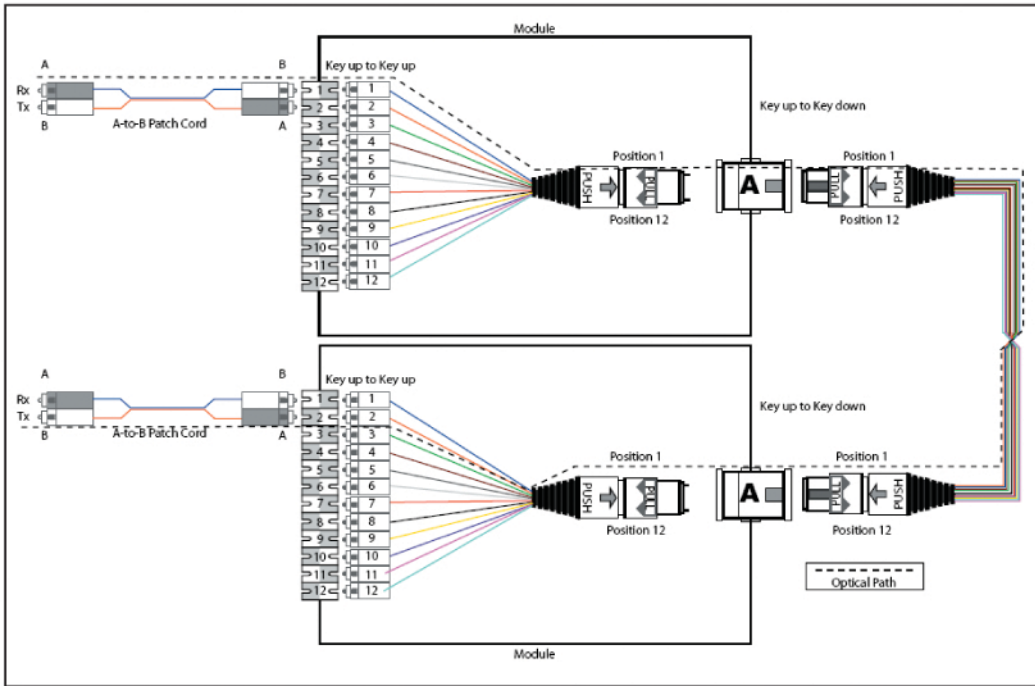

Figure 5: Method C Connectivity

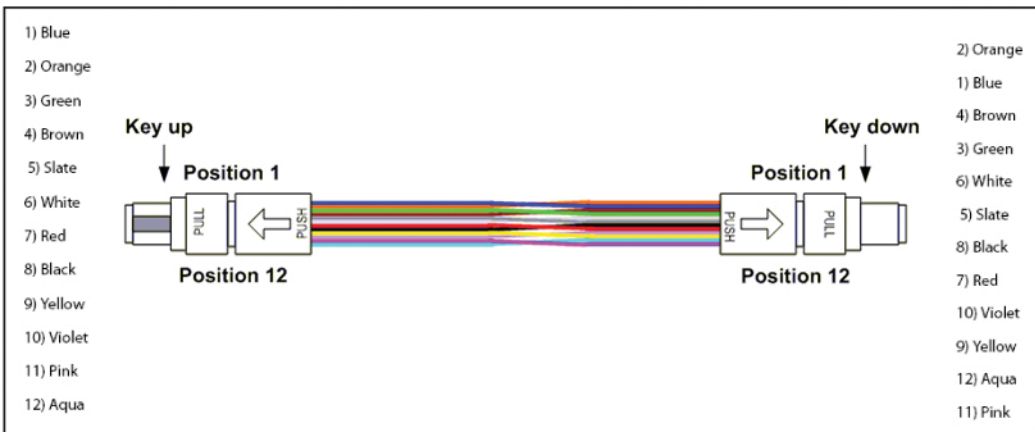

Figure 6: Method C Backbone

The system polarity I require is:-

Method A

Method B

Method C

.....Signature

.....Date